

SPEC. NO. _____

AT020N2C2

Specification

PART NO: 1010200201

Drafted by: _____

Checked by: _____

Approved by: _____

Customer's confirmation:

Company name: _____

Name: _____

Title: _____

Signature: _____

Date: _____

Specification Summary:

Frequency Range (MHz)	824-894	1850-1990
Gain (dBi)	2	
VSWR(max)	2.5: 1	
Impedance (Ω)	50	
Connector	SMA	
Polarization	Vertical	
Color	black	
Dimensions (mm)	52x18x8	
Weight (g)	7	
Accessories		
Application		

Parameters

BAND	GSM Dual Band			
Frequency (MHz)	824	894	1850	1990
Return Loss (dB)	-10.334	-13.602	-8.6753	-16.5
SWR	1.8942	1.5314	2.167	1.3571

Test Results

Return Loss

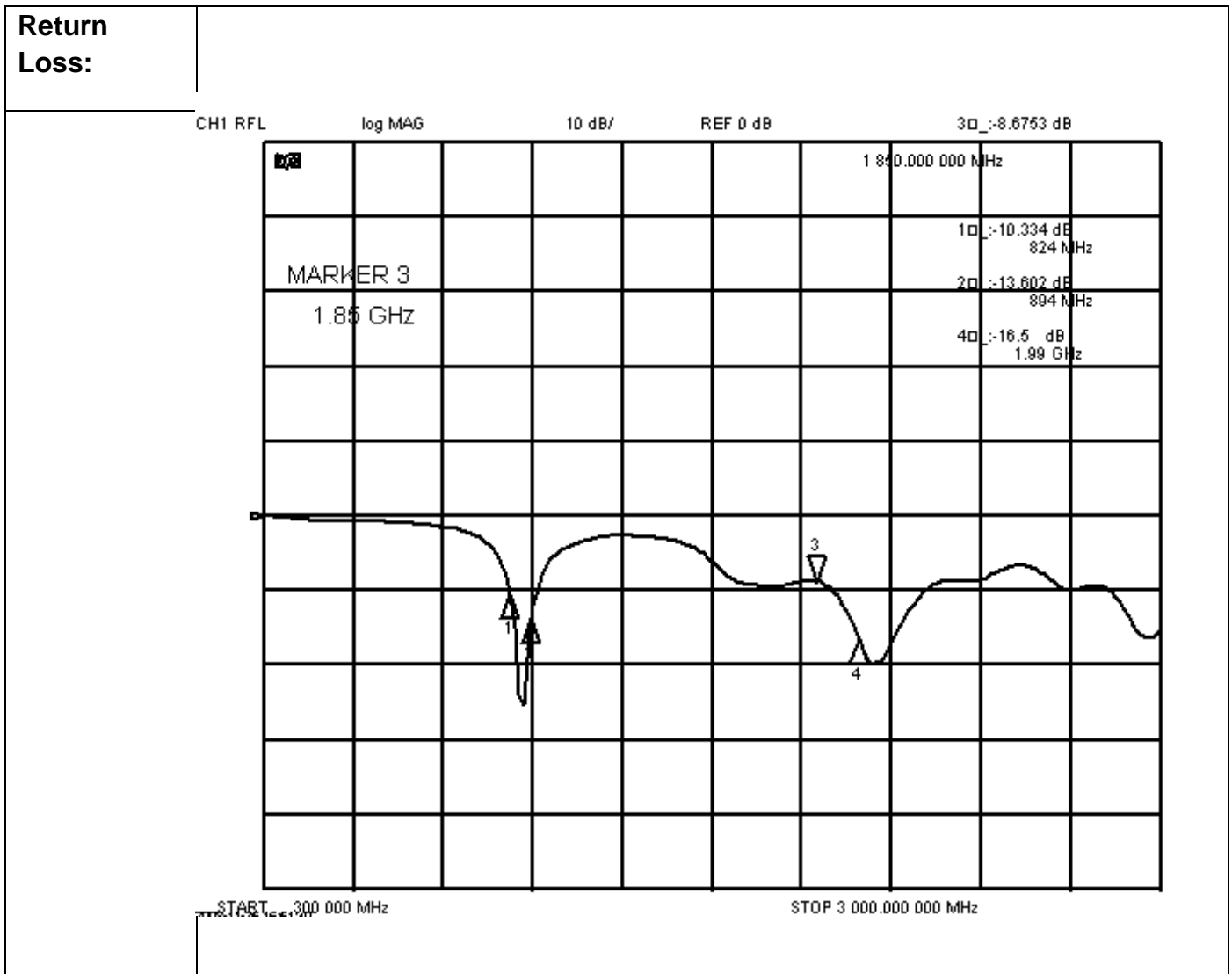

Smith:

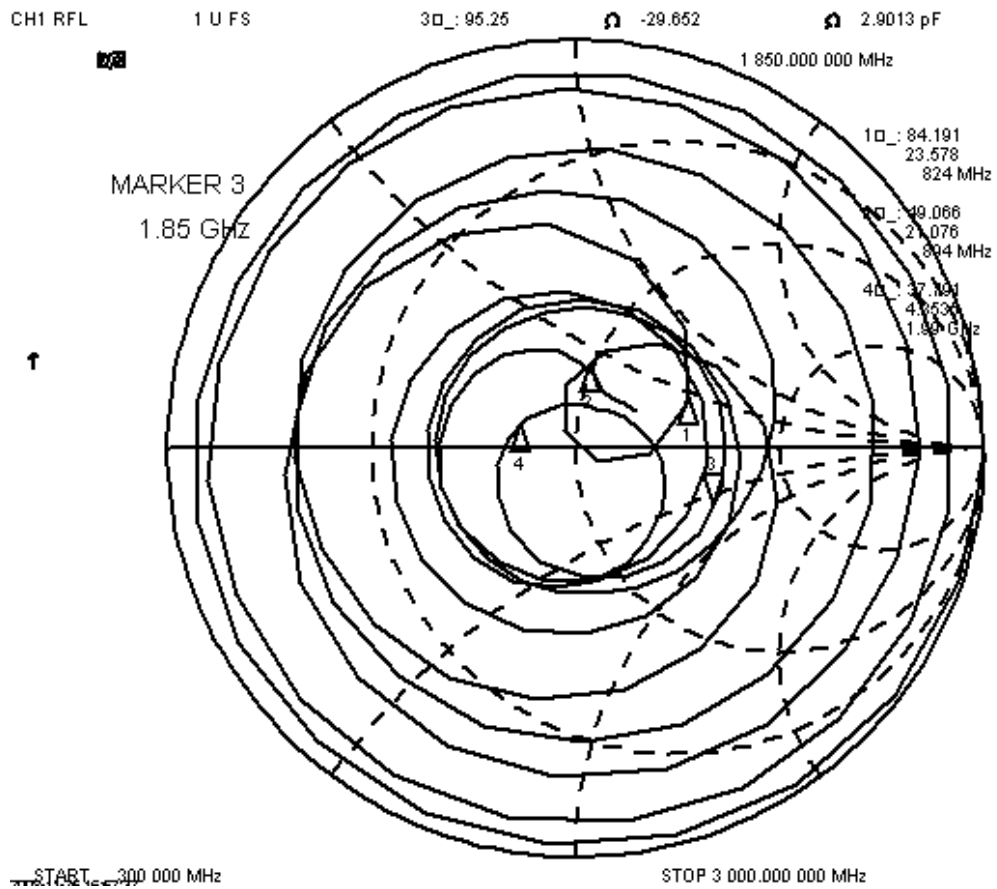

VSWR:

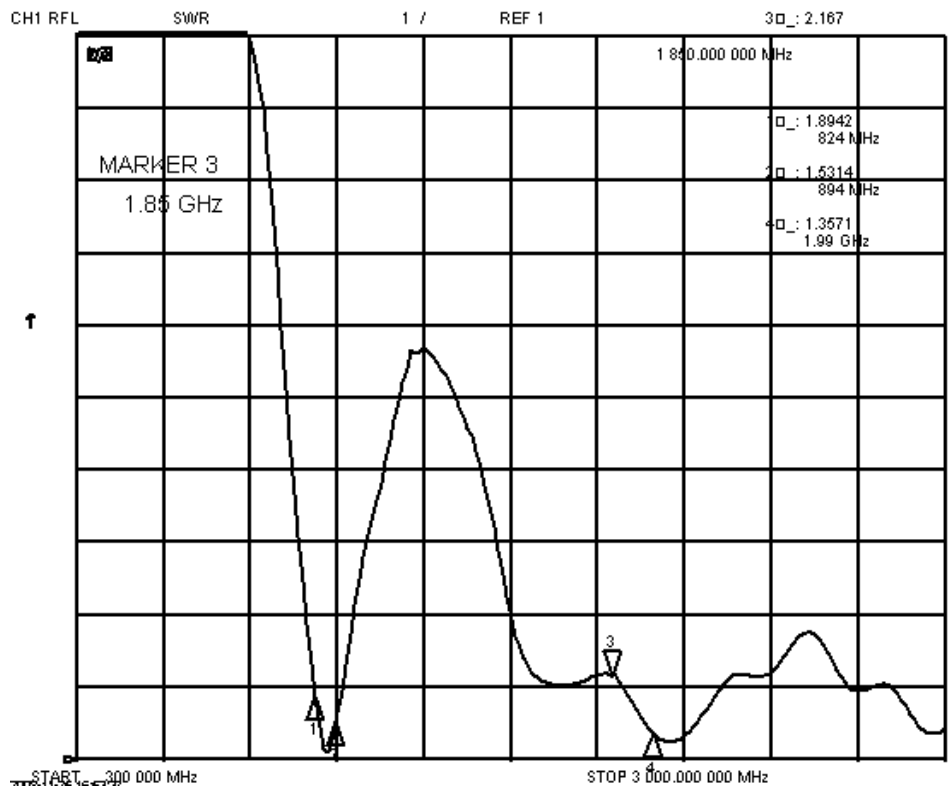

Mechanical Figure

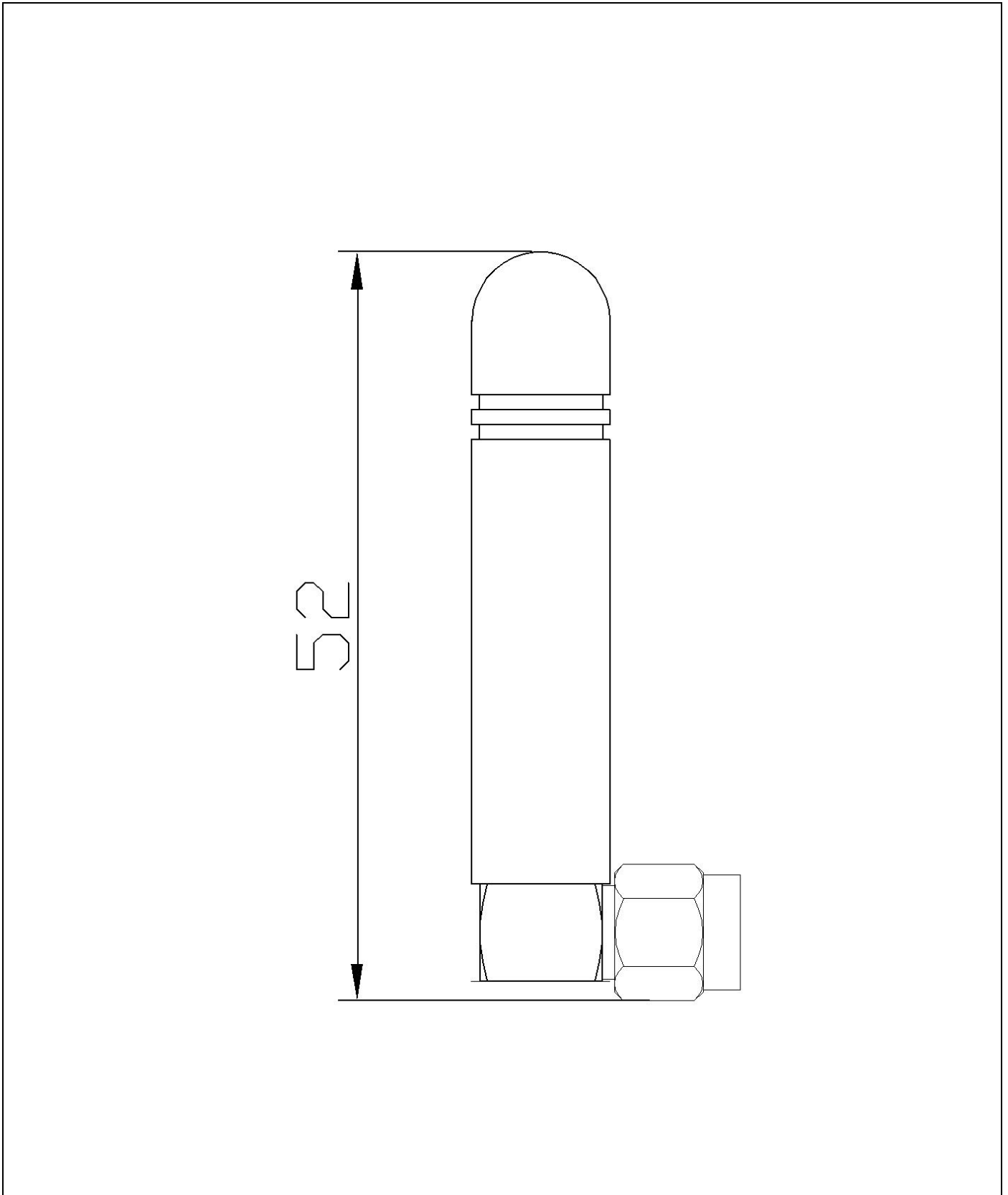

Install sketch map

